



TRANSFORMER BOBBIN
INDUSTRIAL CO.,LTD.

Tel : 86-769-88789999 Fax : 86-769-88789989
http:// tbi-tw.com e-mail : tb6688@ms46.hinet.net

REVISIONS

REV	SYM	DRAFTER	CHECKER	DATE
①		S.M.SHIH	S.M.SHIH	12/25/06
②				
③				

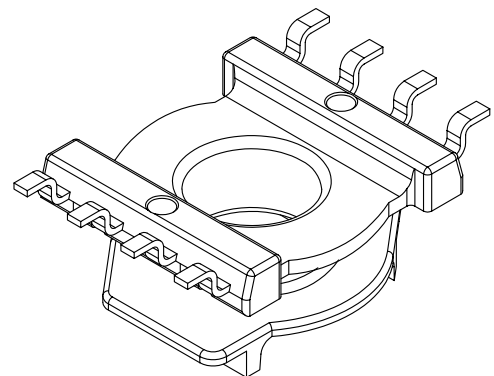
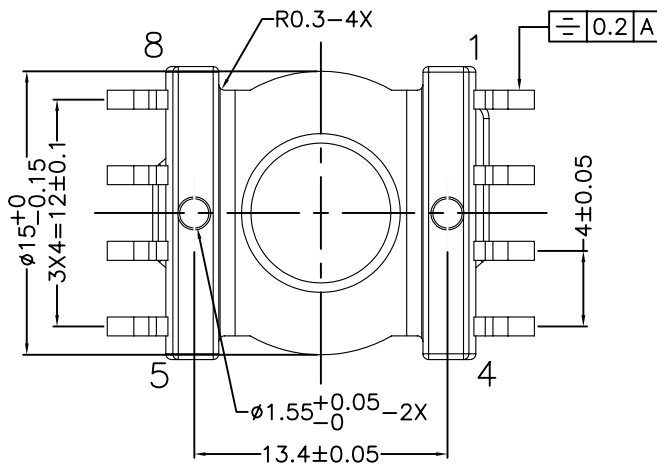
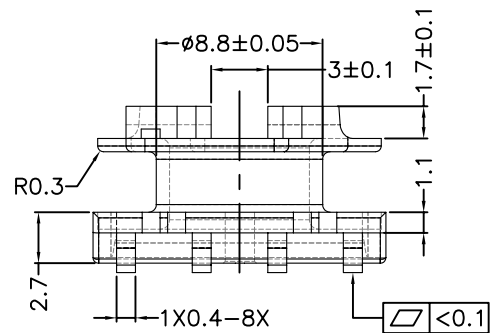
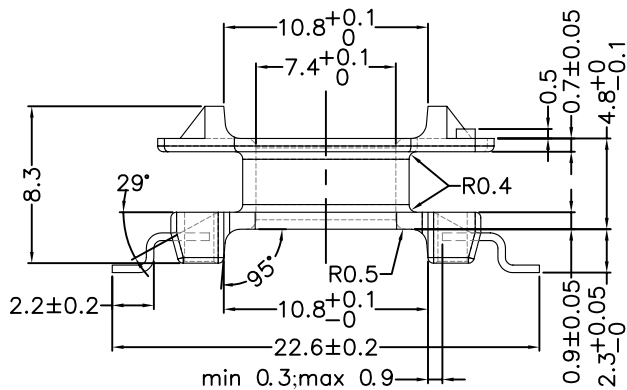
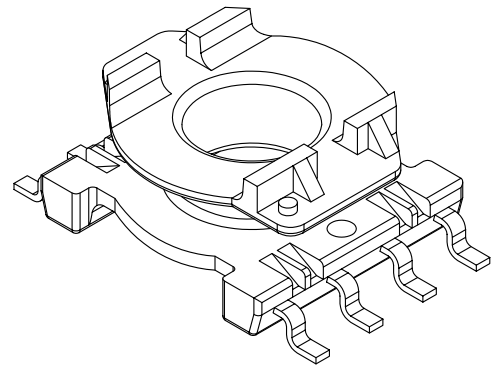
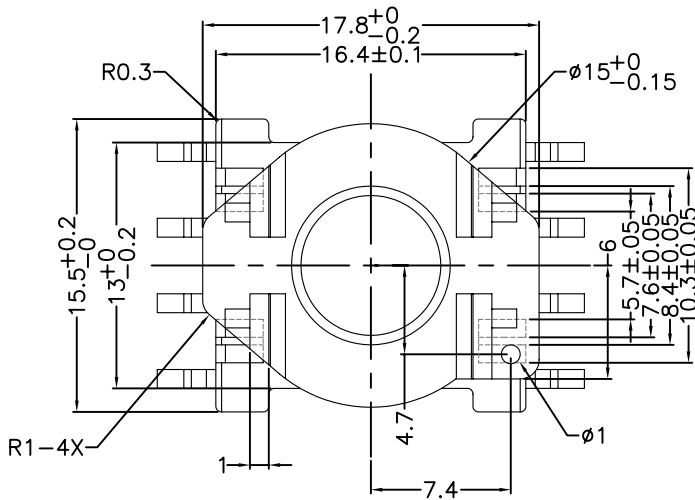

DWG NO. ER19-8P-GW-4.0-0C-1

PART NO.	MATERIAL (BOBBIN)	MATERIAL (TERMINAL)	TERMINAL (PLATING)	PIN ALLOCATION	NOTE
TBI-104-09031.103	PM-9630JT	P.B C5191	Sn	ALL PIN	

TOLERANCE: .X±0.15 .XX±0.10 .XXX±0.05 UNIT : m/m SCALE 2.5 : 1

Finish: 1. Immersion gold on terminal : Thickness gold 0.075 μm (3 μ inches) min, Base nickel 0.625 μm (25 μ inches) min.

② 2. Immersion Sn on terminal : Terminal:Sn plating, 100, 7.5~12.5 μm (300~500 μ inches) min , Base nickel 1.25~2.25 μm (50~90 μ inches) min

3. Coplanarity deviation: 0.10 mm (0.004 inches) max.

REV 1