



**TRANSFORMER BOBBIN  
INDUSTRIAL CO.,LTD.**

Tel : 886-2-22929999 Fax : 886-2-22925236  
 http:// tbi-tw.com e-mail : tb6688@ms46.hinet.net

REVISIONS

REV	SYM	DRAFTER	CHECKER	DATE
△		T.S.LII	W.H.HSU	06/12/01
△		T.S.LII	W.H.HSU	11/01/04
△				

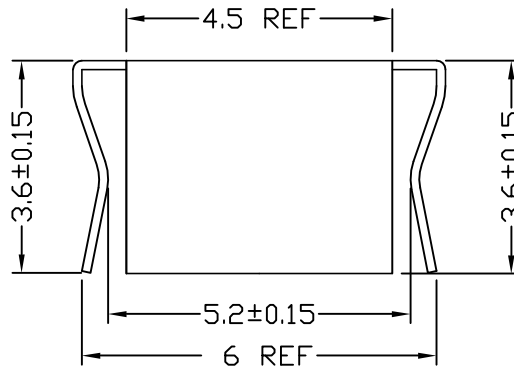
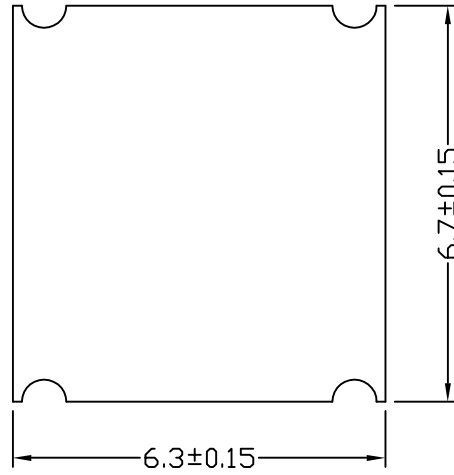

T=0.15

PART NO.	EP5-SMD-CLIP			
DWG NO.	MATERIAL (BOBBIN)	PLATING		BUYER ' S PART NO.
TBI-403-01011.1	SUS 301	NO		

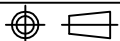

TOLERANCE: .X±0.15 .XX±0.10 .XXX±0.05

UNIT : m/m

SCALE 8 : 1

Finish: 1. Immersion gold on terminal : Thickness gold 0.075 μm (3 μ inches) min, Base nickel 0.625 μm (25 μ inches) min.  
 2. Immersion Sn on terminal : Terminal: Sn plating, 100, 5 μm (200 μ inches) min , Base nickel 0.625 μm (25 μ inches) min.  
 3. Coplanarity deviation: 0.10 mm (0.004 inches )max.

REV 2